

Control exhaust valve KSOM

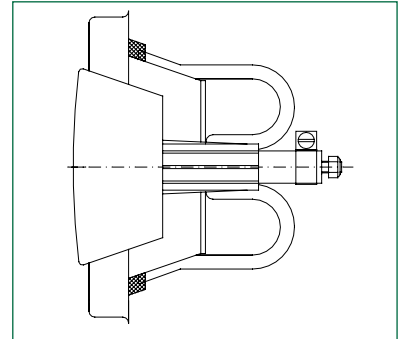

KSOM is ideal for rooms which require forced exhaust air flow. KSOM consists of exhaust valve, control motor and controller card, which are installed in the valve cone. KSOM has an integrated humidity sensor which controls the valve. KSOM is perfect for use for example in the bathrooms of single family homes, terraced houses and apartment blocks. Using various control units, air flow can be controlled to suit the needs of different rooms and changing operating conditions.

Quick-selection

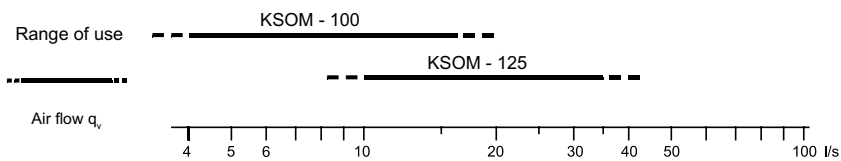

Product facts

Exhaust valve with control motor and controller card.
KSOM includes also a humidity sensor.

Operates within a wide pressure and air flow range.

Low noise level.

Airflow easily measured and controlled.

Augmentation time can be set steplessly for anywhere between 15 minutes to 2 hours.

Suitable for new construction and renovation installation.

Manufactured of steel sheet.

Product code example:

Exhaust air valve KSOM-100

Dimensioning, sound data

Selection diagrams

KSOM-100

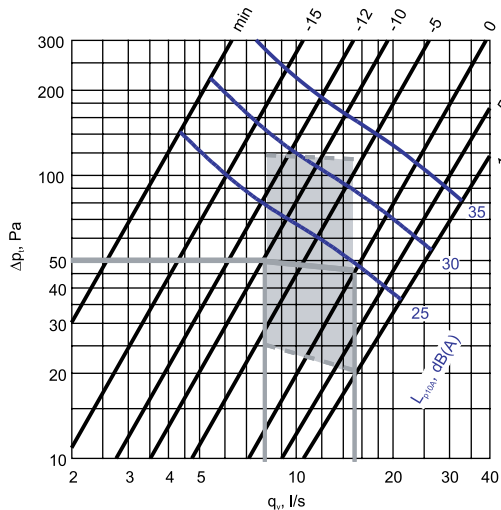

KSOM-125

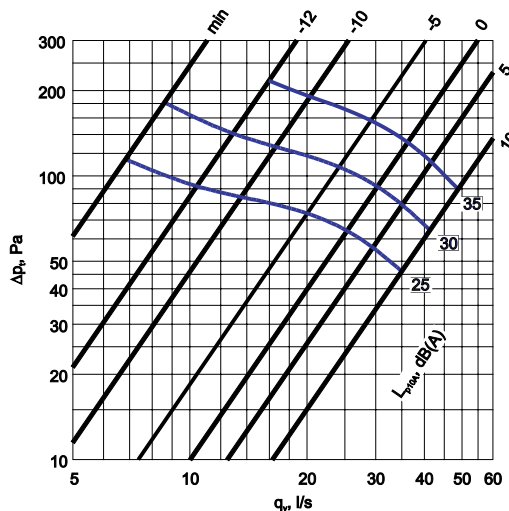

The desired forced exhaust is achieved with the choice of pressure level and forced exhaust position (5, 10, 15 or 20 mm) (see selection diagrams).

Selection example

Bathroom ventilation according to part D2 of the Finnish Code of Building Regulations.

- Normal exhaust 8 l/s and forced exhaust 15 l/s.
- The pressure drop of the air terminal device is defined (e.g. 50 Pa).
- A suitable air terminal device size is chosen (Ø100).
- The normal exhaust adjustment is -10 and the desired forcing is achieved at position 0. The pressure drop from the ducts increases during forced exhaust, in which case the proportion of the total pressure drop to be used by the valve decreases.
- The forced exhaust position is set at 10 mm (increases the air flow from 8 l/s of the normal exhaust to 15 l/s of the forced exhaust)

Ventilation system

The room-specific forced exhaust achieved with KSOM and KSOM valve can be realized according to two principles depending on the ventilation system. The valves can be used as a part of a constant pressure system, in which case the forced exhaust is achieved by increasing the total air flow. When the constant pressure maintaining is not used, the forced exhaust is achieved by "loading" from other rooms.

Selection

KSOM is selected on the basis of the desired basic air flow rate, forced air flow rate and noise level. The used air flow can be adjusted steplessly by turning the screw spindle of the motor.

The valve must however be selected so that the basic adjustment position can be set at -15 ... 0 mm to enable a sufficient forced effect.

Sound power level L_{WV}

KSOM	Correction K_{oct} (dB)							
	Middle frequency by octave band (Hz)							
	63	125	250	500	1000	2000	4000	8000
100	2	-6	-5	0	-2	-1	-9	-16
125	1	2	-3	-1	-4	1	-11	-19
Tol.±	6	3	2	2	2	2	2	3

Sound power levels by octave bands are obtained by adding to the total sound pressure level L_{p10A} , dB(A), the corrections K_{oct} presented in the table according to the following formula:

$$L_{Woct} = L_{p10A} + K_{oct}$$

Correction K_{oct} is an average value in the range of use of the KSOM.

Sound attenuation ΔL

KSOM	Sound attenuation ΔL (dB)							
	Middle frequency by octave band (Hz)							
	63	125	250	500	1000	2000	4000	8000
100	25	20	13	9	10	11	6	7
125	21	16	12	10	9	14	6	6
Tol.±	6	3	2	2	2	2	2	3

Average sound attenuation ΔL from duct to room including the end reflection of the connecting duct in wall installation.

Dimensions and weights, installation

Dimensions and weights

KSOM

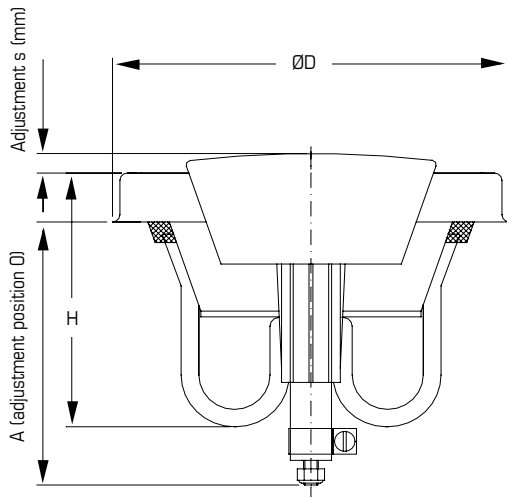

Size	D	d	H	A	Weight, g
100	135	87	89	105	633
125	161	107,5	105	105	755

Extension ring

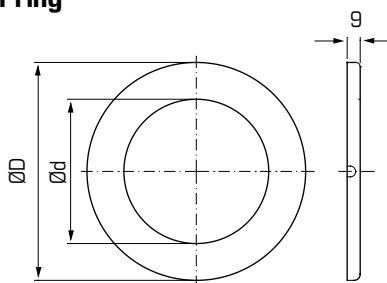

Size	ØA	Ød
100	151	103
125	181	128

Frame

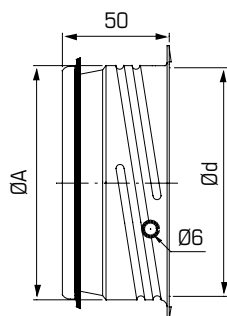

Size	ØA	Ød
100	99,3	98
125	124,3	123

Installation and connecting

The mounting frame delivered with the product is fitted to the duct with rivets. The valve is rotated into the frame.

Detailed instructions in the installation and connecting manual delivered with the product.

The control exhaust valve is delivered with a fixedly installed 1 m cable. This requires placing the connecting box close enough to the valve. The frame / extension ring has a hole for the wire.

In concealed mounting, a protecting tube must be brought from the connecting box to the valve (Fig. 1) to enable the drawing of the cable delivered with the valve to the box. It is not allowed to change the cable delivered with the valve, but it can be extended with a cable satisfying the requirements.

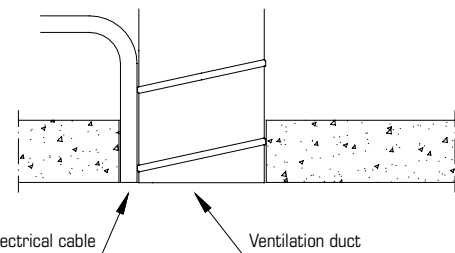

Measurement and regulation of air flow

The air flow is measured by a pressure difference measurement with a separate measuring tube.

The air flow is regulated by changing the position s.

The measuring diagrams and detailed regulation instructions can be found in the installation and connecting instructions delivered with the product.

Definitions

q_v	air flow	(l/s)
Δp_t	total pressure drop	(Pa)
L_{p10A}	sound pressure level with 4 dB room attenuation (10 m ² sab)	[dB(A)]
L_{Woct}	sound power level	(dB)
K_{oct}	correction	(dB)
ΔL	sound attenuation from duct to room	(dB)

Wiring diagrams

KSOM

Controlled with an external switch

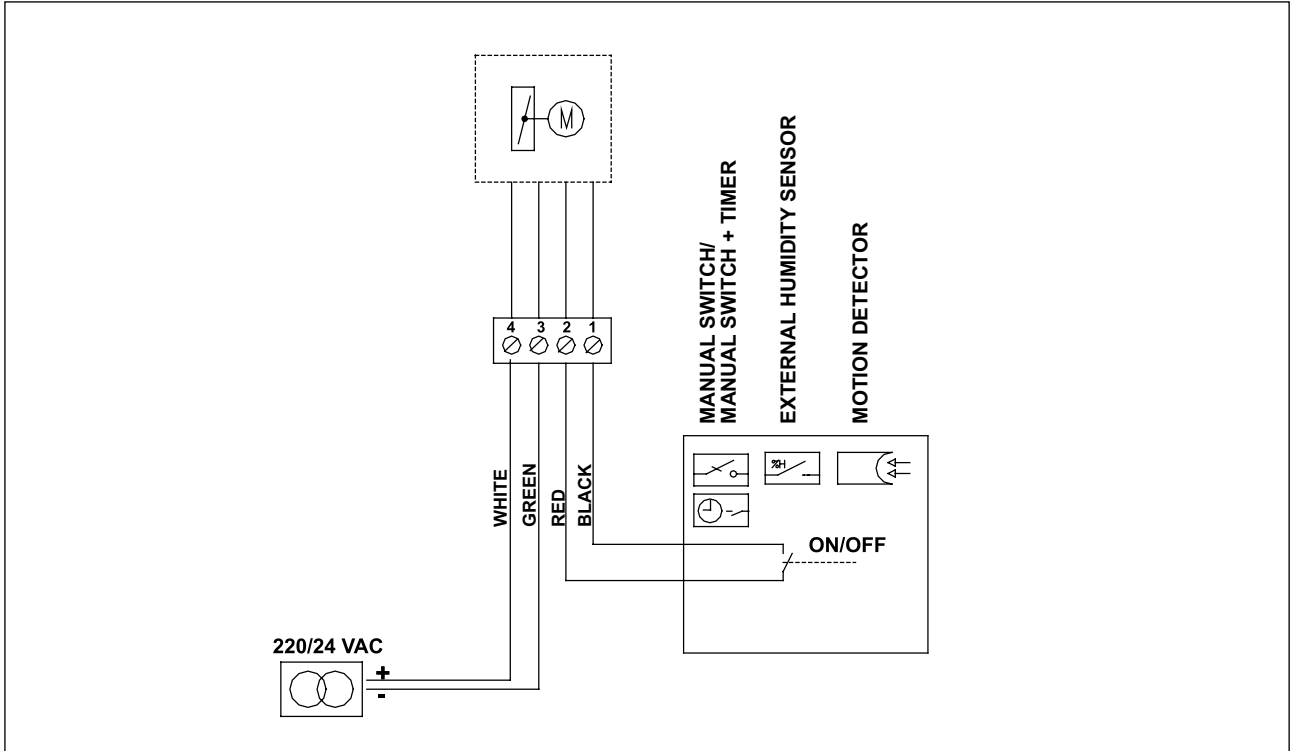

KSOM

Controlled with a humidity sensor integrated in the valve

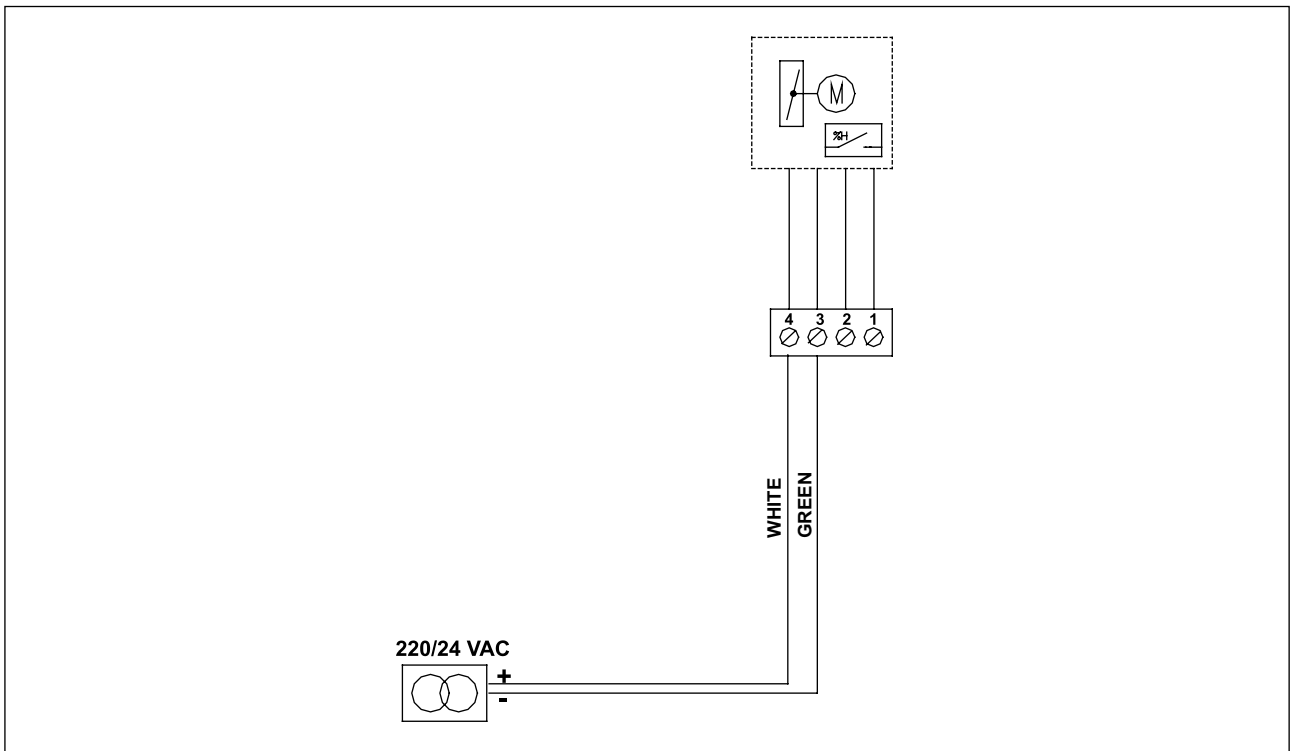

Accessories

Accessories

Manual operating switch	Strömfors Artic PS1
Manual operating switch with timer	Strömfors ATC 10 A
Occupancy sensor (wall) - mounting base for ceiling - mounting base for wall	Calectro PIR-TF-25 MB-95 MB-98
Occupancy sensor (ceiling)	Calectro PIR-TF-25-360
Hygrostat - electronic - mechanical	E + E Electronics EE14 Industrie Technik DBZH

Technical data of the actuator

Supply voltage	24 V AC (protective extra low voltage, SELV) \pm 20 %
Rated power	12 VA / 500 mA
Controlling	With a closing switch
Running time	Max. 6 s
Noise level while running	38 dB(A)
Electric protection	III (protective extra low voltage, PELV)
Enclosure	IPO0
Ambient temperature	+ 10 °C ... + 50 °C
Storage temperature	- 25 °C ... + 65 °C
Humidity	... 100 %
Electromagnetic compatibility	89/336/EY
Safety	98/37/EY
Service	Follow separate manual
Calculated life	100 000 cycles

Choosing transformer

The KSOM valves operate on a voltage of 24 VAC. The transformer size is chosen according to the overall power demand of the devices connected to it. The power demand of one valve is 500 mA / 12 VA. The choice of transformer type is also affected by the placing of the valve and the conditions in its surroundings.

A transformer for one valve is available at Fläkt Woods, see product code.

Application, function, construction, product code

Application

KSOM is ideal for rooms which require forced exhausts. The valve can be opened electrically according to operating conditions (with a manual switch or an occupancy or humidity sensor) It is available in sizes Ø 100 and Ø 125. An extension ring enables surface and concealed mounting for electrical connections.

Function

The basic adjustment of KSOM can be set steplessly when balancing the ducting. The forced exhaust can be set from the controller at 5, 10, 15 or 20 mm (pre-set by the factory at 10 mm).

KSOM has an integrated humidity sensor which controls the valve (forced exhaust RH 65% and return RH 60%).

As well as with an integrated sensor, KSOM can also be controlled externally (e.g. with an operating switch). The integrated sensor can also be disabled with the control switch, enabling only external control.

KSOM controlling with a room-specific controller: see accessories.

In addition, the valve performs an automatic test run every day, irrespective of whether forced ventilation is needed or not.

The valve motor operates with a voltage of 24 VAC.

Construction

KSOM consists of exhaust valve, control motor and controller card, which are installed in the valve cone.

The valve disc contains a control motor with a screw spindle and a controller, with which the disc can be run into the open position. In addition, a plastic tube which prevents the cover from rotating during forced exhaust has been attached to the disc.

The delivery includes a valve with connecting cable, mounting ring and extension ring, with which a free space can be reserved for the connecting cable between the wall or ceiling surface and the frame.

Material

The valve is made of steel sheet and it is stove-enamelled in white. Other colors are available to special order. The valve body is equipped with a cellular plastic sealing gasket.

The mounting ring is made of hot galvanized steel sheet. The airtight mounting ring KKT includes a Veloduct rubber sealing gasket and a wire inlet equipped with an inlet rubber gasket.

Descriptive text

Control exhaust valve KSOM, valve for external control, e.g. KSOM-100 manufactured by Fläkt Woods.

Product code

**Control exhaust valve
(mounting ring included)**

KSOM-aaa

Product with an integrated
humidity sensor

Size
100, 125

Transformer 24 V / 0,5 A

KSOZ-8