

Heat recovery unit RDKR



The RDKR heat recovery unit is a component in the Minimaster and Minivent systems. This unit has been developed from our standard RDKG unit and has an extremely efficient rotary heat exchanger with high temperature efficiency. The unit has a built-in control equipment and can be supplied with an external control panel. It can be connected to a cooker hood if placed in a kitchen. RDKR is primarily intended for homes and small commercial premises. The unit does not need draining, which is a great advantage when replacing existing installations. All units are supplied in right-hand or left-hand versions with all connectors facing upwards. The unit is intended for wall mounting. The cooker hood has a tightly sealed damper that opens when cooking. Exhaust air in the kitchen is arranged through a separate exhaust air valve.

Energy consumption

RDKR is an extremely energy efficient heat recovery unit that reduces energy consumption remarkably. The reduction is possible because the fans are driven by EC motors, which have an energy consumption of only 50 - 60 percent of that of an equivalent AC motor. The RDKR unit also has a rotary heat exchanger. It is so effective that supplementary heating is only needed at outside temperatures of below 10° C.

Air flow chart

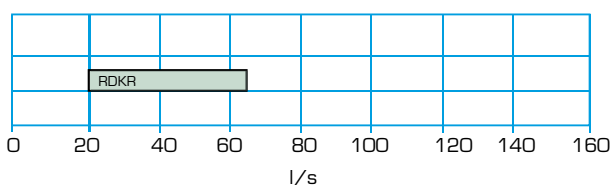

Product data

- Up to 83% temperature efficiency
- Supply and exhaust air flows between 20 - 65 l/s
- Can serve living areas up to 155 m²
- Filters up to class F7
- High efficient EC motors
- Individually adjustable fans
- No need for drainage
- Easy to install
- Service friendly

Product code example

RDKR-1-1-0-2-2

Description, materials, technical data

Casing

The outer and inner casing are made of galvanized sheet metal with 15 mm insulation made of expanded polystyrene. The control electronics inside the protective hatch are easily accessible without the need to open the unit. The unit door is locked with screws.

Fans

The fans are driven by very quiet and energy efficient EC motors. The fans are easy to remove for service and maintenance. The speed of the fans can be independently regulated steplessly.

Heat exchanger

The heat exchanger is an aluminium rotary heat exchanger. It has a temperature efficiency up to 83%.

The unit is fitted with an automatic defrost function controlled by outside temperature. The heat exchanger can easily be removed for cleaning. In the Minimaster system the air from the cooker hood bypasses the heat exchanger to avoid odour exchange.

Preheater and afterheater

The unit is prepared for a built-in electric preheating and afterheating battery. In areas where the rated outside temperature (DUT5) is lower than -25°C the installation is fitted with a preheater. The preheater is controlled by a thermostat. The afterheater in the unit regulates the supply air temperature. The unit can easily be retrofitted with a preheating and afterheating battery.

Filter

The unit is fitted with filters in F5/G3 classes. Filters up to class F7 are available as accessories.

Sound power level in octave bands

The sound power level L_w in octave bands to ducts is calculated by adding the correction factor (with the relevant characters) to the sound power level L_{wt} read off diagram 1.

Sound path correction, dB	Octave band, mid-frequency Hz					
	63	125	250	500	1000	2000
Supply air	+5	+6	-1	-5	-6	-15
Extract air	+4	+3	0	-4	-5	-15
Exhaust air	0	-3	-11	-15	-22	-30
Outdoor air, dB	-2	-3	-11	-15	-25	-33

Sound level

Sound level L_{A10} is shown for a room with a 10 m^2 sound-absorption area. To obtain the true sound level the following are added dB(A) values (with the relevant characters) to the value read in diagrams.

Area of room	Normally furnished room	Heavily furnished room, a kitchen for example
5 m^2	+2 dB(A)	+7 dB(A)
10 m^2	0 dB(A)	+4 dB(A)
15 m^2	-1 dB(A)	+1 dB(A)

Supply air fan

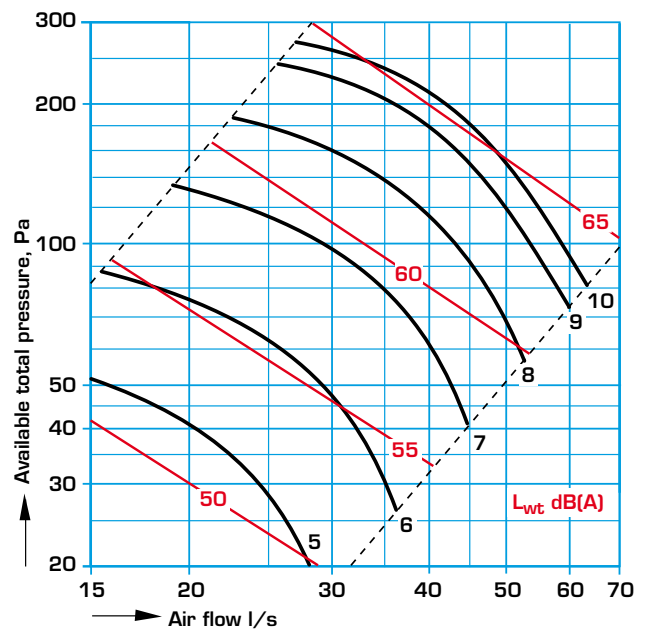

Diagram 1. a) Supply air fan, potentiometer setting (V)
b) Sound to duct, L_{wt} , for supply air fan
c) Filter F5

Exhaust air fan

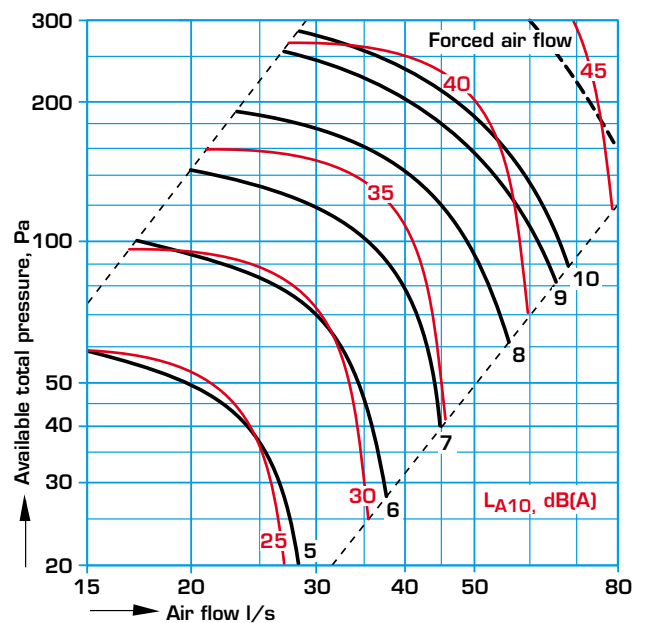
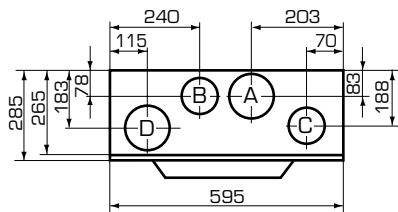
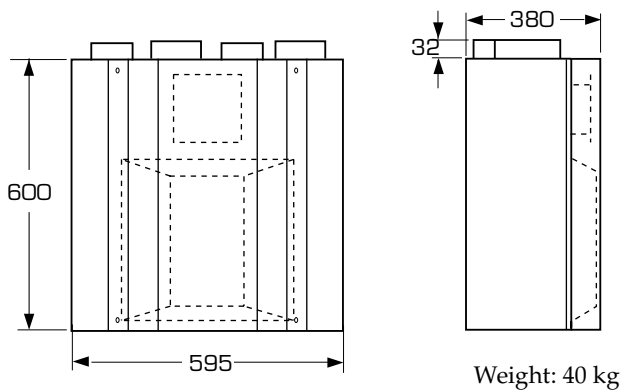

Diagram 2. a) Exhaust air fan, potentiometer setting (V)
b) Sound to kitchen, L_{A10} , from unit with the forced air damper in the cooker hood closed
c) Filter G3

Dimensions, electrical data, control equipment

Dimensions and weight



RDKR-1
Connection -
outdoor air right, supply air right

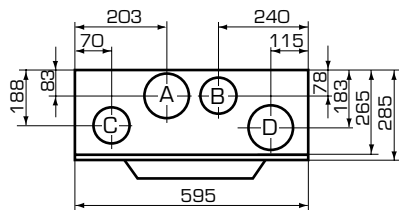

RDKR-2
Connection -
outdoor air left, supply air left

Conn. (female)	A	B	C	D
Diameter	125	100	100	125
	Supply air	Exhaust air ¹⁾	Outdoor air ¹⁾	Extract air

¹⁾ Increased to $\varnothing 125$ as space permits.

Electrical data

Voltage: 230V, single phase 50Hz

Code	Fan motors rated output, W	Preheater Electric, W	Afterheater Electric, W	Rated output Electric, W ¹⁾	Rated output with cooker hood
RDKR	2 x 82	500	500	1170	1210

¹⁾ Rated output when both preheater and afterheater are installed.

Packaging

The unit is supplied in a cardboard box. Mounting brackets for wall mounting and all instructional documentation are enclosed.

Control equipment

The unit is supplied with an electronic control unit, located behind the protective hatch. It regulates the fan, the rotary heat exchanger and possible electric heater.

Fan control

There is three different modes that can be chosen through the control panel (accessory):

- "AWAY" is used when nobody will be at home for a longer period to save energy.
- "HOME" is used for normal ventilation.
- "FORCED" is used when there is a greater need of ventilation (it will automatically return to the "HOME" mode after 120 minutes).

The control panel (accessory), that can be installed at desired location, has a button with an arrow on it that is used to choose mode.

The fans can also be controlled through a cooker hood when the unit is installed in a kitchen. The air flow is set in forced mode automatically when the damper in the cooker hood is open.

The speed of the fans can be adjusted independently of one another. The air flow of the three different modes can be regulated with a potentiometer on the circuit board. There is normally only need for adjusting the air flow of the "HOME" mode.

Temperature control

The control unit regulates the rotary heat exchanger and potential preheater and afterheater to deliver the desired temperature. There are two different energy modes:

- In the "NORMAL" position, the supply air temperature is adjusted to the desired reference value in two stages. As a first stage with the energy recovery from the rotary heat exchanger, and, if this is insufficient, as a second stage with the electrical after heater.
- In the "REDUCED" position, the impeller and the electrical afterheater have separate reference values. The supply air temperature is first adjusted to the desired reference value with the energy recovery from the rotary heat exchanger. If the impeller is not able to recover sufficient heat, the electrical after heater is used, but with a reference value that is 2° C lower than the normal reference value.

In both energy operating modes, the electrical afterheater can only heat the supply air if the rotary heat exchanger is in operation. The heat recycling can get too high during some periods of the year and result in a slightly higher temperature which has to be accepted in order to save energy.

The control unit handles defrosting during very cold periods when frost may develop on the heat exchanger. This occurs when the outdoor temperature drops below -10°C.

Alarm

The control panel (accessory) has an alarm to indicate when it is time to change the filter and also temperature alarm. An external alarm such as fire alarm can be connected to stop the unit from operating.

Accessories, product code

Accessories

Control panel RDKZ-41

External control panel for installation on wall. There is three different settings for choosing the fan speed; "AWAY" for saving energy, "HOME" and "FORCED" air flow. The control panel also has a temperature alarm and filter replacement indicator lamp.

Combined air terminal device RDKZ-26

The combined air terminal device takes in outdoor air and removes extract air from the heat recovery device serving a home. It is mounted on an outside wall. Outdoor air is taken in at the bottom and extract air is blown straight out. Both openings are fitted with screens. The screen over the extract air opening can be easily removed for inspection and cleaning.

Air intake BSDB-20

For positioning on outside walls. The intake consists of a box which has a outside wall grille as a rain guard. So it does not need to be positioned where it is not exposed to rain.

Ventilation hood CBAE-12

Used for the extract air from the heat recovery unit. It is connected to sheet metal ducting or flexible steel tubing.

Pipe insulation RDKZ-45

For condensation and heat insulation for ducts routing cold air through heated spaces. Pipe insulation consists of nonflammable cellular polyethylene plastic. The thickness of the insulation is 15 mm and it comes in one metre lengths. Pipe insulation is pushed on from the end of the duct.

Silencer BDER-38

Rectangular silencer for 125 mm diameter pipes.
L x W x H = 1000 x 250 x 175.

Noise attenuation at	Centre frequency, Hz							
	63	125	250	500	1k	2k	4k	8k
BDER-38-012-100	13	12	18	34	46	43	44	24

Product code

Heat recovery unit RDKR-a-b-c-d-e
with rotary heat exchanger

Connection (a) _____
1 = Outdoor air right
2 = Outdoor air left

Electric heater (b) _____
0 = Without
1 = Only afterheater
2 = Afterheater and preheater

Front cover (c) _____
0 = Without front cover
(for front cover see RDKZ-14 below)

Filter Supply air/Exhaust air (d) _____
2 = F5 bag filter/G3 flat filter

Generation (e) _____
2

Accessories

Spare filter RDKZ-13-b-c
Supply air/Exhaust air (b) _____
1 = G3
2 = F5
3 = F7

Generation (c) _____
1

Front cover RDKZ-14-b-c-d-e
Material (b) _____
3 = White painted
4 = Stainless steel

Extension part against ceiling (c) _____
0 = Without
1 = With (+300 mm)

Height (d) _____
6 = 600
7 = 700

Generation (e) _____
1

Installation cable for control panel RDKZ-43-b-cc-d
Model (b) _____
1 = 6-pole flat kabel

Lenght (cc) _____
10 = 10 m
25 = 25 m

Generation (d) _____
1

Control panel RDKZ-41-1
Electric heater for retrofitting RDKZ-12-001
(can serve as preheater as well as afterheater)

Cooker hood for RDKR-1-b-c-d-2 CPDJ-b-cc-d-1-1
Cooker hood for RDKR-2-b-c-d-2 CPDJ-b-cc-d-2-1

Combined air terminal device RDKZ-26-000
Air intake BSDB-20-012
Ventilation hood CBAE-12-111
Pipe insulation ø 100 RDKZ-45-010
Pipe insulation ø 125 RDKZ-45-012
Silencer BDER-38-012-100