

SUPPORTING BASEMENT

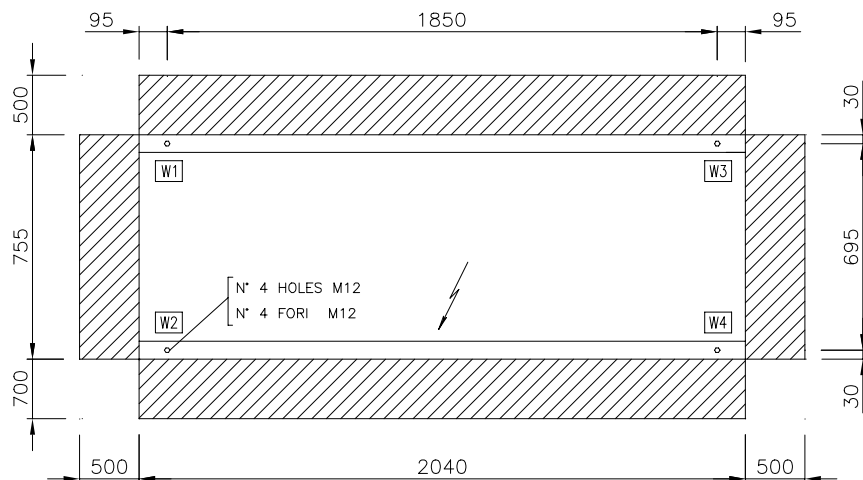

DISTRIBUZIONE PESI - WEIGHT DISTRIBUTION (Kg)					
GRANDEZZA SIZE	W1	W2	W3	W4	TOTAL
HRH/H 0524	233	232	233	232	930
HRH/H 0604	247	246	247	246	985

- ① ENTRATA ACQUA EVAPORATORE 2 x Ø2" GAS
EVAPORATOR WATER INLET 2 x Ø2" GAS
- ② USCITA ACQUA EVAPORATORE 2 x Ø2" GAS
EVAPORATOR WATER OUTLET 2 x Ø2" GAS
- ③ ENTRATA ACQUA CONDENSATORE 2 x Ø2" GAS
CONDENSER WATER INLET 2 x Ø2" GAS
- ④ USCITA ACQUA CONDENSATORE 2 x Ø2" GAS
CONDENSER WATER OUTLET 2 x Ø2" GAS
- ⑤ INGRESSO LINEA ELETTRICA
POWER INLET

2	SUPPORTING BASEMENT MODIFIED		
REV. N°	DESCRIPTION		
DESCRIPTION: WATER COOLED LIQUID CHILLERS HRH/H 0524-0604		DRAWING N°	REV. N°
		D4425500-1	D4425500-2
DRAWN	DATE 20/04/2000	SUBSTITUTES N°	SCALE 1:17
AUDITEN	DATE 20/04/2000	SUBSTITUTES BY N°	SHEET 1 OF 1
		BY TERM OF LAW THIS DRAWING CANNOT BE REPRODUCED WITHOUT OUR WRITTEN AUTHORIZATION	

ALLEGATO N°2-3