

Air heater for hot water, pipe connection

- EQEE Air heater for hot water
- EQCE Air heater for hot water
- EQEG Air heater for anti-freeze protection

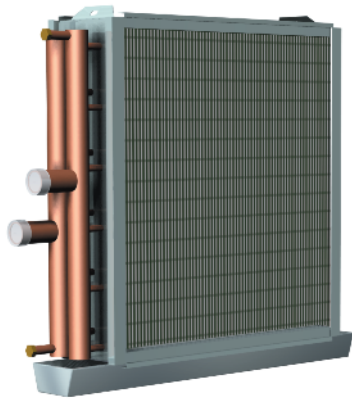

- EQKE Air heater for hot water, ductmounted
- EQDE Air heater for hot water, ductmounted

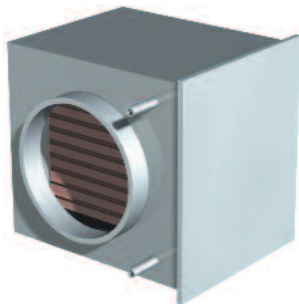

To connect the Air Heater

Connections to the pipework should be made by the pipework contractor. Connect the finned heat exchanger to the pipework in such a manner that the deadweight of the pipework won't be applied to the liquid connections.

The liquid connections are provided with identification plates for the inlet and outlet.



Caution! Use a pipe wrench to restrain the pipe connections of the heat exchanger when tightening the external pipe connections.

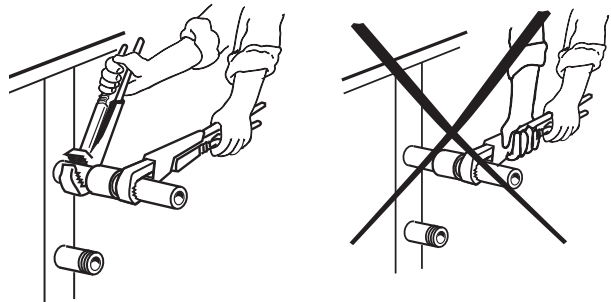

Frost Protection Sensor

In applications where the air heater is equipped with a nipple and finned tubes, fit an insertion-type sensor as frost protection. Position the insertion sensor first in the direction of airflow, i.e. on the return pipe.

If the air heater does not have finned tubes, fit a strap-on sensor to the return pipe. Apply heat-conducting paste between the pipe and the sensor for good contact.



Caution! When installing air heaters where the heating medium is water at a temperature exceeding 100 °C, great care should be taken when opening the venting taps and isolating valves in the system. Failure to do so will result in serious damage due to water hammer or escaping steam.

Fläkt Woods assumes no responsibility for the connection of air heaters to the heating system, or any damage resulting from faulty planning, installation or maintenance of such a system. Pipes, valves, etc., should be sized with regard to pressure drop and satisfactory operation and not to suit the dimensions of the air heater connections. Pipes should be installed in such a way that neither the weight of the pipe system nor the forces due to expansion of the pipes are brought to bear upon the air heater.

Air heater for hot water, pipe connection

Air heater for hot water

Make sure that the outlet water temperature does not drop abnormally and that water circulation is maintained. The valves should then be open, the pipework and coils should be thoroughly purged of air, and the circulation pump should be in operation, even if the heating system is temporarily shut down, such as during the night.

Anti-freeze protection on the air side

The anti-freeze thermostat should have a bulb as the sensor. A long capillary tube is theoretically better, but is poorer in practice, since correct fitting may be difficult or sometimes impossible to achieve. Apply the bulb along the second tube from the water outlet, reckoned on the warm air side. If the capillary tube is too long, coil it up and place it adjacent to the thermostat housing.

Location of thermostat which is not temperature-compensated

The thermostat housing must be located in a place in which the temperature is higher than the intended tripping temperature. In a cold plant room, it must be installed in the air stream.

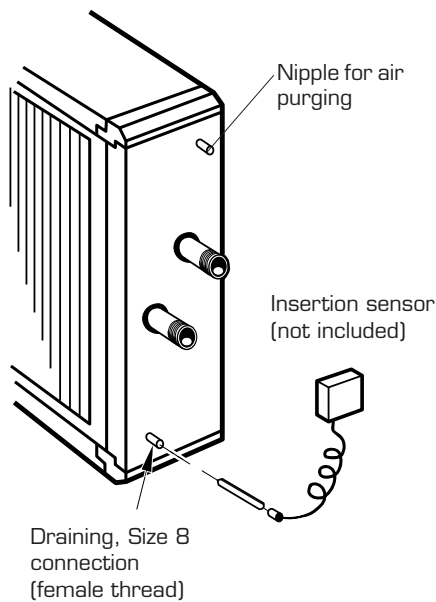



Important!

- The air heater casing is often cold, since unheated air flows immediately on the inside of the casing. If the thermostat housing is mounted on the air heater casing, as is commonly the case, it should not be fitted directly to the casing but should be insulated from it by means of a panel of fibreboard or some similar material.

Cleaning

Even an efficient air filter cannot remove all the dust from the air. Any dust deposits on the heat transfer surfaces restrict the airflow and impair the heat transfer. The finned coil body must therefore be kept clean. Cleaning should preferably be carried out according to any or a combination of the methods below.

- A. Blowing clean with compressed air.
- B. Blow clean with steam.

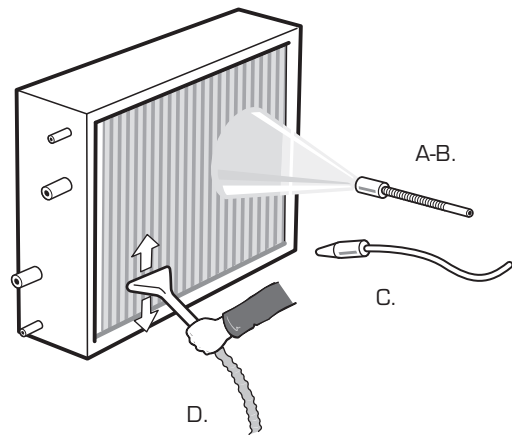

- C. Flush or rinse with water (at up to 40 °C for coils with evaporative refrigerant). If the heat transfer surfaces are coated with a fatty deposit, add a suitable detergent.
- D. Vacuum-cleaning

After cleaning, remove all fallen dust before starting the fan. Clean the drain tray, if fitted. Also check that the water trap has been cleaned and filled with water.



Caution!

The heating elements are still hot after you have switched off the unit. You risk getting burned if you touch them. Switch off the unit well in advance before cleaning.

Air heater for hot water, pipe connection

Measures to be taken if there is risk of freezing

If the water in a coil should freeze, the coil will burst. This will allow the water to run out of the system, which may cause water damage.

Freezing is likely to occur in ventilation systems under the following conditions at low outdoor air temperatures:

1. The temperature of the heating medium is too low. Freezing is especially likely to occur in the autumn and in the spring. Adjust the water temperature to suit the outdoor air temperature.

2. The finned heat exchanger is oversized. Set the water temperature to a lower setting so that the water flow will increase.

3. The heat supply to the air heater ceases or is reduced. If the supply of heat to the air heater is expected to cease or be significantly reduced, the outdoor air intake must then be adequately closed and all the fans must be stopped.



NOTE!

If the heat supply has ceased or decreased, open the air recirculation damper. The pressure in the premises may then drop to sub-atmospheric value, even though the fans are not running. Outdoor air will then be drawn through the unit and may cause freezing and consequent bursting.

The anti-freeze protection must not be adjusted to such a low temperature that freezing is likely to occur.

If the building is left unheated for a longer period of time in the winter, the water must be drained from both the pipework and the heat exchangers. Don't refit the plugs to the heat exchangers before the systems is to be refilled with water. To make certain that the heat exchanger is completely drained of water, blow compressed air through it.

Draining

Do not screw on the drain plugs after emptying, as there is risk that valves may leak and refill the finned-coil body.

Fins

Use the EQAZ-14 fin aligning comb for straightening any deformation of the fins.

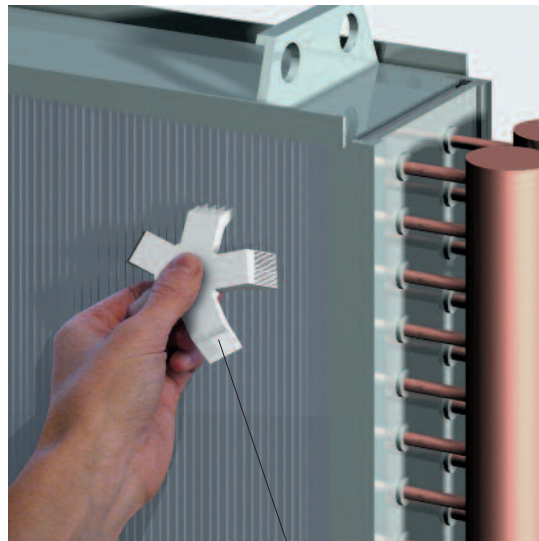

Fin comb EQAZ-14



Important! Wear protective gloves whenever working with the fin alignment comb.

Venting







The finned coil body can be vented through the pipe system.

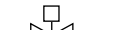
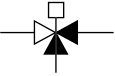

WARNING
Warning for hot water!

Air heater for hot water, pipe connection

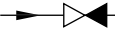
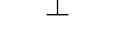
Symbols used in Figs. 4-5 and 7-15

-  = Air heater for hot water
-  = Shut-off valve
-  = 2-way throttling valve, manual
-  = 2-way control valve, automatic
-  = 3-way control valve, automatic (the unfilled arrow point always indicates a fully open valve)
-  = Thermometer
-  = Non-return valve
-  = Measuring tapping
-  = Pump (the point of the arrow indicates the direction of the flow)
-  = Direction of the flow

General information concerning control

For best result each heating coil should be provided with its own circulation pump (see Fig. 3). This ensures an even circulation of the water in the air heater, regardless of the position of the control valve; and provides the following important benefits:

1. Appreciably less risk of freezing, due to the fact that the water velocity in the coil is always sufficiently high.
2. Substantially better regulating characteristics. This is a consequence of the advantageous ratio between the pressure drop across the control valve and the pump discharge pressure. This ratio is also known as the valve authority "A".

In the case of an air heater fitted with its own circulation pump and connected as shown in Fig. 3, the valve authority is always 100%.

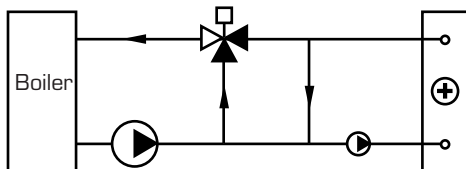

Fig. 4. Air heater with circulation pump.

Example: Assume that the air heater does not have its own circulation pump (see Fig. 4). With a pressure drop across the control valve and air heater of 400 and 600 mm WG respectively, the authority will be.

$$A = \frac{400}{400 + 600} = 0,4 = 40\%$$

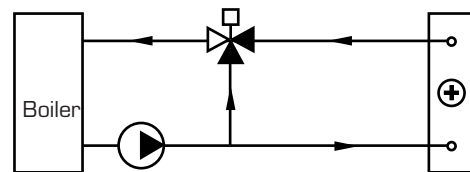

Fig. 5. Air heater without circulation pump.

As will be seen from the chart (Fig. 6), the water flow q_r will not be significantly reduced when the opening h is reduced from the fully open position. In order to reduce the water flow q_r by 50%, the valve opening must be reduced to 0.37.

Control is further complicated by the fact that the heating capacity of an air heater is not proportional to the water flow, the heating capacity in normal cases is reduced by 15%.

In the example above, it will be seen that when the valve opening is reduced to 0.37, as much as 85% of the heating capacity is obtained. A significant reduction in heating capacity is therefore obtained only over a very small part of the valve stroke.

If the pressure drop across the control valve is low in relation to that across the air heater, regulation will be even less efficient. At a pressure drop of 55 mm WG in the example above, the authority will be only 10%. According to Fig. 6, the valve opening must be reduced to 0.18 in order to obtain half the water flow, while the heating capacity will still be 85%.

As mentioned previously, each air heater should be provided with its own circulation pump and should be connected as shown in Fig. 4.

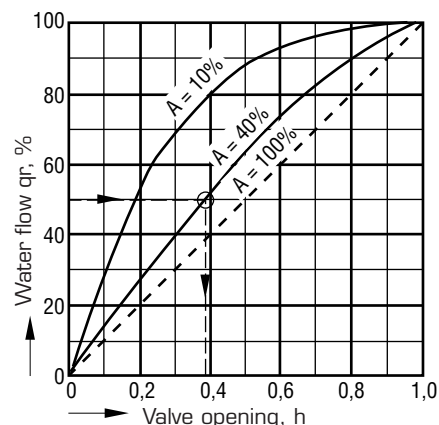

Fig. 6

Air heater for hot water, pipe connection

Circulation pump fitted in supply pipe

The air heater should be connected as shown in Fig. 7. If the temperature of the return water is to be as low as possible, e.g. as in the case of the district heating plants, connections should be made as shown in Fig. 8.

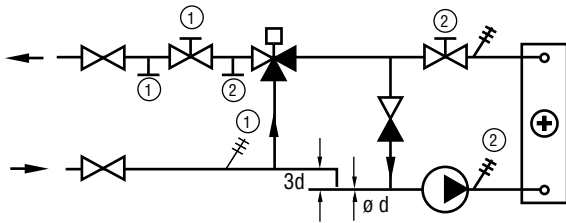

Fig. 7. Normal connection of the air heater.

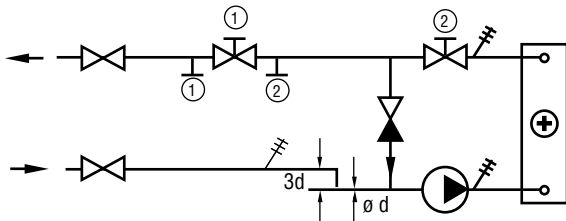



Fig. 8. Connection of an air heater for lowest possible return water temperature.

The circulation pump of the air heater should be located in the water supply pipe and be sized for the maximum required flow and for the pressure drop in the air heater and the secondary circuit. The pump in the main circuit should cover the pressure drop across the control valve.

The measuring points should be arranged as shown in Figs. 7 and 8 respectively. Throttling valves with built-in measuring nipples are available on the market. If throttling valve No. ① is of this type, measuring points ① and ② are not required. A suitable connection size for the measuring points is 6 mm (1/4" BSP).



NOTE! The non-return valve, when fitted as shown in Figs. 7 and 8 must permit flow downwards. Should this not be possible, the pipework package (shunting unit) should be arranged in Z form or some other suitable arrangement.



Air heater for hot water, pipe connection

Circulation pump connected in shunt

Fig. 9 shows a connection that must be avoided, partly because it is very difficult to regulate, and partly because it may improve the control characteristic only to a limited extent. In many cases, the characteristic will be worse.

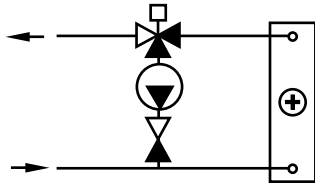

Fig. 9. Air heater with circulation pump connected in shunt.

Connection without circulation pump

If for some reason a circulation pump is not installed, the pressure drop across the control valve must be at least as high (and preferably double) as the pressure drop across the hot water air heater coil. The regulating valve port on the air heater coil side should have a logarithmic characteristic.

The regulating valve should be mounted as shown in Figs.10 or 11.

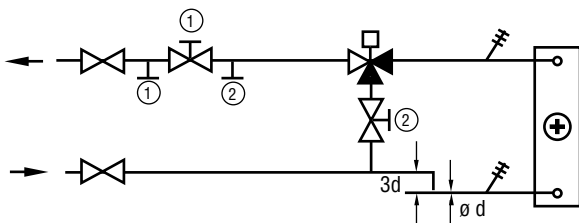

Fig. 10. Connection of air heater without circulation pump.

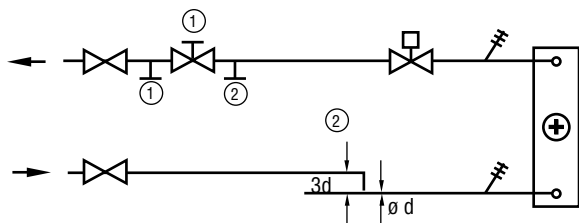

Fig. 11. Connection of air heater without circulation pump for lowest possible return water temperature.

Pipe connection

Fig. 12 shows a correct connection and Fig. 13 an incorrect connection. All pumps should be fitted in the supply pipe, whereas all throttling and control valves should be located in the return pipe. This gives the greatest possible pressure in the air heaters, thereby reducing the risk of operational troubles due to air in the air heater coil. To permit isolation of the coils, two valves should be installed in close proximity to the inlet and outlet connections of the air heater coils.

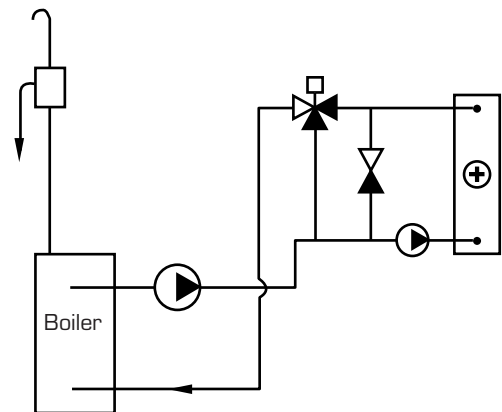

Fig. 12. Correct connection of piping system.

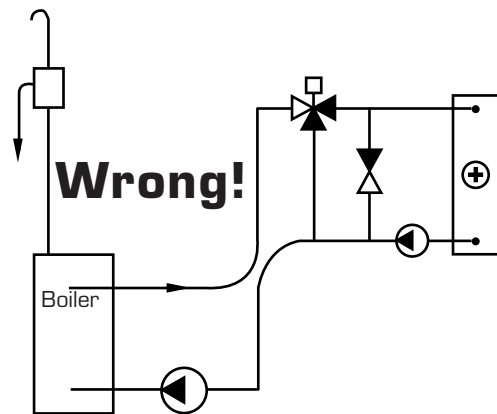

Fig. 13. Incorrect connection of piping system.

Air heater for hot water, pipe connection

Venting

The venting device should be arranged with the air collecting chamber directly in the pipe and in such a way that the water velocity will not exceed 0.2 m/s. Both an automatic venting valve and a manual valve should be fitted on the vent chamber (see Fig. 13). Maximum venting reliability is obtained when the venting device is mounted at the highest point of each pipe (see figure on the left).

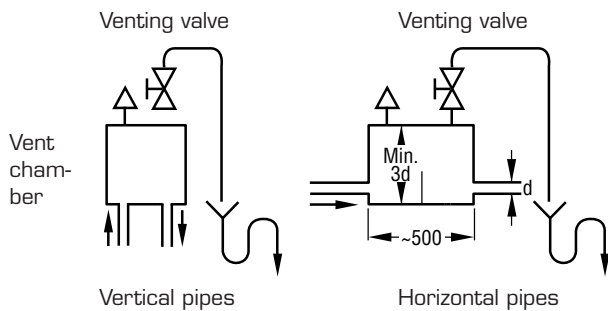

Fig. 14. Venting of vertical and horizontal pipes

In a venting device mounted on a horizontal pipe, a deflector plate should be fitted in the centre to deflect the water flow upwards. Fig. 14 shows the incorrect arrangement of the venting device. Owing to the high water velocity in the main pipe and the relatively small size of the venting pipe, the air cannot reach the venting system.

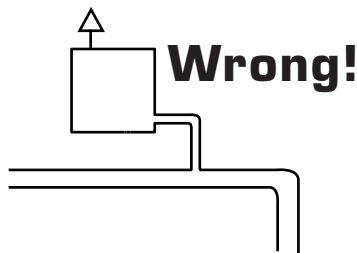

Fig. 15. Incorrect arrangement of venting

Connection of valves

The valves should be connected in accordance with the instructions supplied by the manufacturer.

A seat valve with three ports should be mounted as a mixing valve in the return pipe.



Note! In the case of control valves having a port with logarithmic characteristics, this port must face the air heater coil. This arrangement will provide the best relationship between valve opening and heating capacity.

Adjustment

The connections recommended in the foregoing allow for simple and reliable adjustment.

Connection according to Fig. 7 on page 3

Open the control valve fully.

Connect a pressure gauge to the measuring points ① and ② at throttle valve ①.

Set throttling valve ①, so that a pressure drop corresponding to the calculated flow required is obtained.

Adjust throttling valve ② so that thermometers ① and ② indicate the same temperature.

Check the pressure drop across throttling valve ①.

If necessary, repeat this procedure until a balance has been obtained in which both the main pump and the circulation pump give the correct water flow.

Connection according to Fig. 8 on page 3

Open the control valve fully.

Connect a pressure gauge to measuring points ① and ②.

Adjust throttling valve ② so that the pressure drop across the control valve corresponds to the calculated water flow.

Connection according to Fig. 10 on page 4

Open the control valve fully.

Connect a pressure gauge to measuring points ① and ②.

Adjust the throttling valve 1 until the correct pressure drop across the regulating valve is obtained.

Close the regulating valve and repeat the procedure. Adjust throttling valve ② until the pressure drop equals the value obtained previously.

Connection according to Fig. 11, page 4

Open the control valve.

Connect measuring points ① and ②.

Adjust the throttling valve ① until the correct pressure drop is obtained across the control valve.